

Z og C profiler



INDHOLD

Z og C profiler	03 - 05
-----------------------	---------

NORDIC PANELS RÅDGIVNING TIL ØGET VÆRDI

Stål åse holder hvad de lover og strækker sig rigtig langt.
Standard sortimentet og åsens fleksible form skaber mulighed
for konstruktive løsninger med mange fordele.

**Kompetent produktvejledning, beregning og stærk logistik bidrager til iøjens-
faldende forskel og tryghed i Nordic Panels leverancer.**

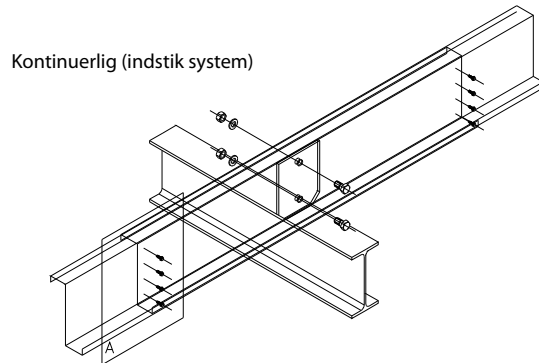
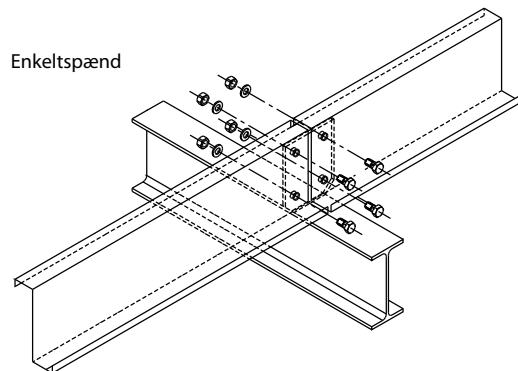

Profiles Z, C, Σ

Z, C, Σ are manufactured from cold rolled steel. Their stiffness and strength parameters allow for wide application in load-bearing structures. Among most typical use of such profiles are the following:

- construction of casing and partition walls,
- laying of floor beams and eaves,
- wall beams,
- roof purlins.

These sections are the supplement to light development system and cladding for industrial, commercial and service facilities.

Openings

Z, C, Σ sections may have assembly openings (\varnothing 14 mm, \varnothing 18 mm, bean shaped 19x25 mm). This makes their assembly with screws or rivets easier. Because of the possibility to

disassemble the construction and its reuse, it is recommended to use screws.

Material

Galvanised steel tape (grade S280 GD or S350 GD), from 1.50 to 3.00 mm thick. Depending on their use and requirements, sections do not need any additional protection, although they can be powder painted.

Standard hulplaceringer åse

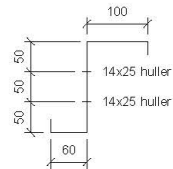

S150

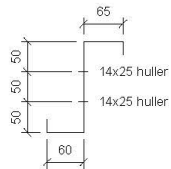

Z150

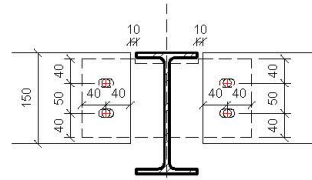

Placering ift Stålrige

(Ø14 huller i åselapper)

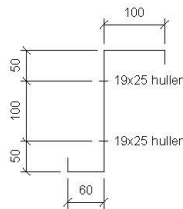

S200

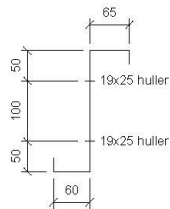

Z200

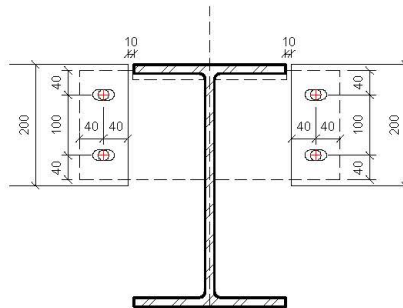

Huller i åselapper

(Ø18 huller i åselapper)

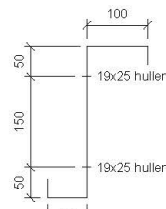

S250

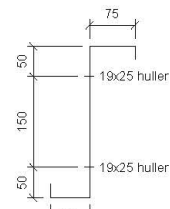

Z250

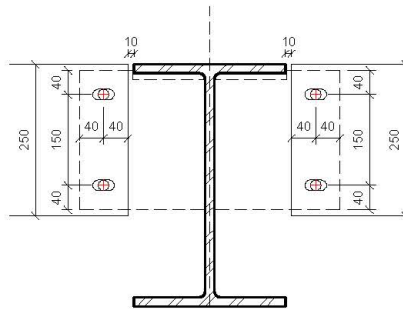

Huller i åselapper

(Ø18 huller i åselapper)

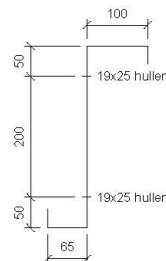

S300

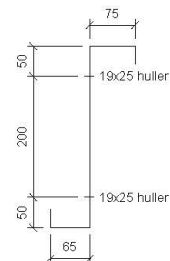

Z300

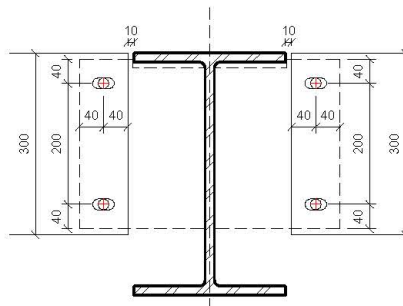

Huller i åselapper

(Ø18 huller i åselapper)

TYPE S åse er med ekstra bred overflange som bruges ved længesamlinger på taget og ved ovenlys i kip

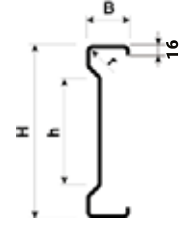
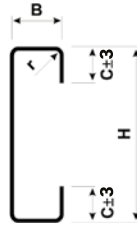
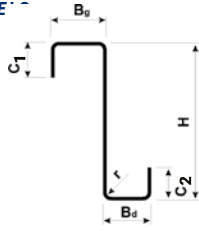

„Z” profiles

	Sheet thickness mm	Weight kg/m	H mm	Bd mm	Bg mm	C ₁ mm	C ₂ mm
Z 100	1,50	2,64	100	48	53	20	20
	2,00	3,52	100	48	53	20	20
	2,50	4,40	100	48	55	20	20
	3,00	5,28	100	48	55	20	20
	3,50	6,16	100	47	60	20	20
Z 100	1,50	3,00	100	60	68	20	23
	2,00	4,00	100	60	68	20	23
	2,50	5,00	100	60	68	20	23
	3,00	6,00	100	60	68	20	23
	3,50	7,00	100	60	68	20	23
Z 150	1,50	3,24	150	48	53	20	20
	2,00	4,32	150	48	53	20	20
	2,50	5,40	150	48	55	20	20
	3,00	6,48	150	48	55	20	20
	3,50	7,56	150	47	56	20	20
Z 150	1,50	3,60	150	60	68	20	23
	2,00	4,80	150	60	68	20	23
	2,50	6,00	150	60	68	20	23
	3,00	7,20	150	60	68	20	23
	3,50	8,40	150	60	68	20	23
Z 180	1,50	3,96	180	60	68	20	23
	2,00	5,28	180	60	68	20	23
	2,50	6,60	180	60	68	20	23
	3,00	7,92	180	60	68	20	23
	3,50	9,24	180	60	68	20	23
Z 200	1,50	3,84	200	48	53	20	20
	2,00	5,12	200	48	53	20	20
	2,50	6,40	200	48	55	20	20
	3,00	7,68	200	48	55	20	20
	3,50	8,96	200	47	56	20	20
Z 200	1,50	4,20	200	60	68	20	23
	2,00	5,60	200	60	68	20	23
	2,50	7,00	200	60	68	20	23
	3,00	8,40	200	60	68	20	23
	3,50	9,80	200	60	68	20	23
Z 250	1,50	4,80	250	60	68	20	23
	2,00	6,40	250	60	68	20	23
	2,50	8,00	250	60	68	20	23
	3,00	9,60	250	60	68	20	23
	3,50	11,20	250	60	68	20	23
Z 250	1,50	4,97	250	65	75	22	25
	2,00	6,62	250	65	75	22	25
	2,50	8,24	250	65	75	22	25
	3,00	9,89	250	65	75	22	25
	3,50	11,54	250	65	75	22	25
Z 300	1,50	5,69	300	65	75	22	25
	2,00	7,58	300	65	75	22	25
	2,50	9,32	300	65	75	22	25
	3,00	11,18	300	65	75	22	25
	3,50	13,04	300	65	75	22	25
Z 350	1,50	6,24	350	65	75	22	25
	2,00	8,32	350	65	75	22	25
	2,50	10,40	350	65	75	22	25
	3,00	12,48	350	65	75	22	25
	3,50	14,56	350	65	78	22	25
Z 400	1,50	6,79	400	65	75	22	25
	2,00	9,06	400	65	75	22	25
	2,50	11,32	400	65	75	22	25
	3,00	13,58	400	65	75	22	25
	3,50	15,84	400	65	75	22	25
Z 350	1,50	6,48	350	75	85	25	28
	2,00	8,64	350	75	85	25	28
	2,50	10,80	350	75	85	25	28
	3,00	12,96	350	75	85	25	28
	3,50	15,20	350	75	85	25	28
Z 400	1,50	7,08	400	75	85	25	28
	2,00	9,44	400	75	85	25	28
	2,50	11,80	400	75	85	25	28
	3,00	14,16	400	75	85	25	28
	3,50	16,52	400	75	85	25	28

„C” profiles

	Sheet thickness mm	Weight kg/m	H mm	B mm	C mm
C 100	1,50	2,64	100	48	18
	2,00	3,52	100	48	18
	2,50	4,36	100	48	18
	3,00	5,23	100	48	18
	3,50	6,10	100	48	18
C 100	1,50	2,88	100	60	19
	2,00	3,84	100	60	19
	2,50	4,76	100	60	19
	3,00	5,71	100	60	19
	3,50	6,66	100	60	19
C 150	1,50	3,24	150	48	18
	2,00	4,32	150	48	18
	2,50	5,36	150	48	18
	3,00	6,43	150	48	18
	3,50	7,50	150	48	18
C 150	1,50	3,60	150	60	19
	2,00	4,80	150	60	19
	2,50	5,96	150	60	19
	3,00	7,15	150	60	19
	3,50	8,34	150	60	19
C 200	1,50	3,84	200	48	18
	2,00	5,12	200	48	18
	2,50	6,36	200	48	18
	3,00	7,63	200	48	18
	3,50	8,90	200	48	18
C 200	1,50	4,20	200	60	22
	2,00	5,60	200	60	22
	2,50	6,96	200	60	22
	3,00	8,35	200	60	22
	3,50	9,74	200	60	22
C 250	1,50	4,50	250	48	19
	2,00	6,00	250	48	19
	2,50	7,40	250	48	19
	3,00	8,88	250	48	19
	3,50	10,36	250	48	19
C 250	1,50	4,80	250	60	21
	2,00	6,40	250	60	21
	2,50	7,96	250	60	21
	3,00	9,55	250	60	21
	3,50	11,14	250	60	21
C 300	1,50	5,02	300	48	18
	2,00	6,69	300	48	18
	2,50	8,28	300	48	18
	3,00	9,94	300	48	18
	3,50	11,60	300	48	18
C 300	1,50	5,33	300	60	21
	2,00	7,10	300	60	21
	2,50	8,72	300	60	21
	3,00	10,46	300	60	21
	3,50	12,20	300	60	21
C 350	1,50	6,26	350	75	20
	2,00	8,35	350	75	20
	2,50	10,40	350	75	20
	3,00	12,48	350	75	20
	3,50	14,56	350	75	20
C 400	2,50	11,32	400	75	20
	3,00	13,58	400	75	20
	3,50	15,84	400	75	20

„Σ” profiles

	Sheet thickness mm	Weight kg/m	H mm	h mm	B mm
Σ 140	1,50	3,84	140	30	70
	2,00	5,12	140	30	70
	2,50	6,24	140	30	70
	3,00	7,49	140	30	70
	3,50	8,74	140	30	70
Σ 170	1,50	4,20	170	60	70
	2,00	5,60	170	60	70
	2,50	6,84	170	60	70
	3,00	8,21	170	60	70
	3,50	9,58	170	60	70
Σ 200	1,50	4,56	200	90	70
	2,00	6,08	200	90	70
	2,50	7,44	200	90	70
	3,00	8,93	200	90	70
	3,50	10,42	200	90	70
Σ 230	1,50	4,96	230	120	70
	2,00	6,56	230	120	70
	2,50	8,04	230	120	70
	3,00	9,65	230	120	70
	3,50	11,26	230	120	70
Σ 260	1,50	5,28	260	150	70
	2,00	7,04	260	150	70
	2,50	8,64	260	150	70
	3,00	10,37	260	150	70
	3,50	12,10	260	150	70
Σ 300	1,50	5,76	300	190	70
	2,00	7,68	300	190	70
	2,50	9,44	300	190	70
	3,00	11,33	300	190	70
	3,50	13,22	300	190	70
Σ 350	1,50	6,36	350	240	70
	2,00	8,48	350	240	70
	2,50	10,44	350	240	70
	3,00	12,53	350	240	70
	3,50	14,62	350	240	70